

P500 Pump Series

Capacities to 1255.1 LPH - Rated to 173 Bar

Electronic Precision Metering

- Designed to handle a wide range of fluids from clear water to thick slurries
- Electronic flow control increases accuracy and reliability
- Multiple diaphragm design provides linear, virtually pulse-less flow
- Smaller footprint saves valuable space
- One pump covers a wide range of flows and pressures - reducing inventory requirements with fast, simple field conversion
- Duplexing option doubles capacity and equipment savings
- Hydraulically-actuated, balanced diaphragms provide superior performance across entire pressure range
- Rugged construction with a variety of affordable choices for liquid end, diaphragm and check valve materials

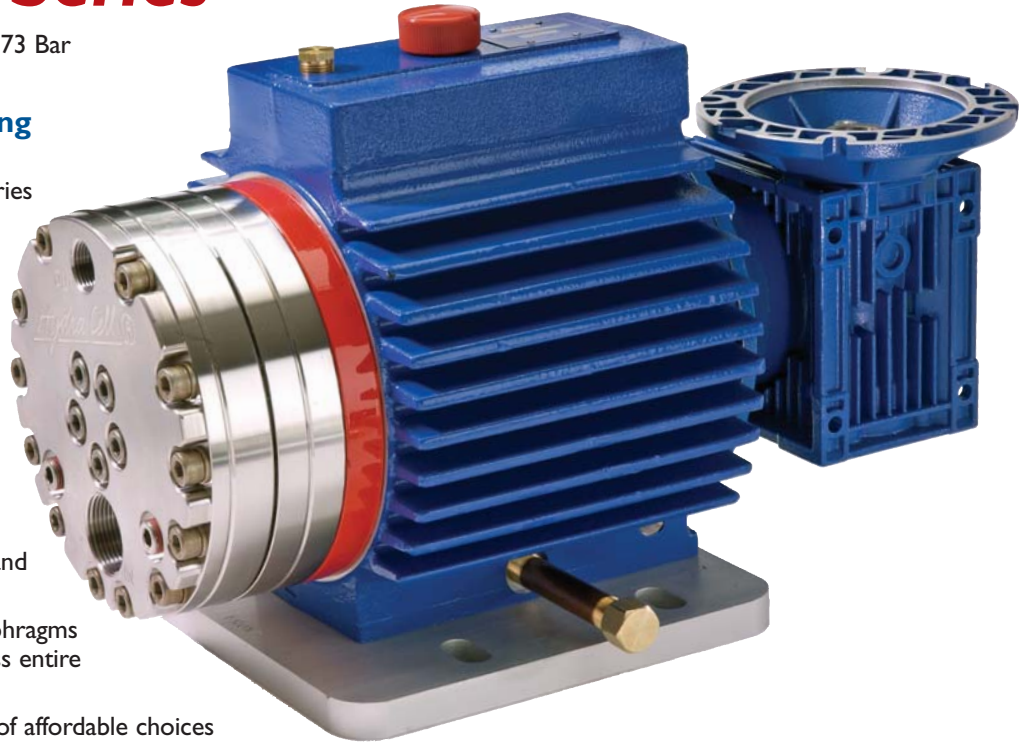

Hydra-Cell Metering Solutions meet or exceed API 675 performance standards for Steady-State Accuracy ($\pm 1\%$), Linearity ($\pm 3\%$), and Repeatability ($\pm 3\%$).

Performance

LPH Maximum Flow at Designated Pressure

LPH Metallic Pump Heads Only				Pump RPM	Gear Ratio	Motor RPM
7 Bar	35 Bar	104 Bar	173 Bar			
36.60	34.90	31.32	28.70	14.5	100:1	1450
44.71	42.93	39.07	36.10	18.13	80:1	
58.20	56.28	51.98	48.40	24.17	60:1	
68.99	66.96	62.30	58.23	29	50:1	
85.19	82.99	77.79	73.00	36.25	40:1	
112.2	109.7	103.6	97.60	48.33	30:1	
133.8	131.1	124.3	117.3	58	25:1	
166.2	163.1	155.2	146.8	72.5	20:1	
220.2	216.6	206.9	196.1	96.67	15:1	
328.1	323.4	310.1	294.5	145	10:1	
436.1	430.3	413.4	392.9	193.33	7.5:1	
652.0	644.1	619.9	589.8	290	5:1	
838.1	828.2	797.9	759.4	373.3	7.5:1	
1255.1	1241.0	1196.8	1139.6	560	5:1	

Required Motor kW

0.18	0.37	0.55	0.75	1.1
1.5	2.2	3.7	5.5	7.5

P500 Pump Series

Pump Data

Diaphragms per Liquid End	5
Flow Control	Electronic variable speed drive
Maximum Discharge Pressure	
Metallic Head:	173 bar (2500 PSI)
Maximum Suction Pressure	35 bar (500 PSI)
Maximum Temperature	
Metallic Head:	121 °C (250 °F)*
Suction Port	1-1/4 inch BSPT or NPT
Discharge Port	3/4 inch BSPT or NPT
Weight (less motor)	
Metallic Head:	72.6 kg (160 lbs)
Dimensions (less motor)**	
Metallic Head:	488 mm W x 272 mm D x 315 mm H (19.2" W x 10.7" D x 12.4" H)

* Consult factory for correct component selection for fluid temperatures above 71 °C (160 °F).

** For 71 B5 motor frame only. Consult factory for other motor frame sizes.

Representative Dimensional Drawings (in mm)

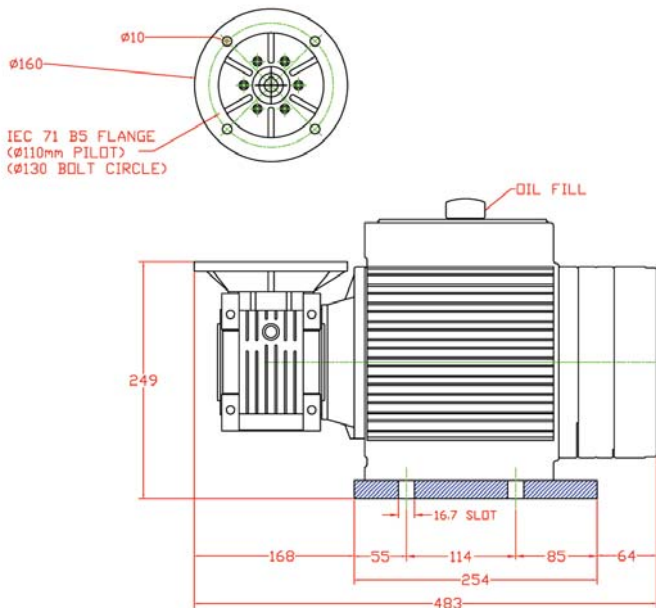

Hydra-Cell Metering Solutions pump systems are available with back pressure and relief valves, calibration cylinders, pulsation dampeners, manifolds and flanges, suction accumulators, custom controllers, strainers, a variety of actuating oils, witnessed and non-witnessed testing, drawing packages, and OEM paint and nameplate customization.

For information on the complete line of Hydra-Cell Metering Solutions pumps, contact us today.

Wanner International Ltd.

Units 8 & 9, Fleet Business Park
Sandy Lane
Church Crookham, Hampshire GU52 8BF, England
Tel: +(44) 01252 816847
FAX Tel: +(44) 01252 629242
Email: sales@wannerint.com
www.WannerInt.com

Printed in USA P500-DS-I-04.07

Wanner Pumps Ltd.

Room 1111, 11/F New Kowloon Plaza
38 Tai Kak Tsui Road
Tai Kak Tsui, Kowloon, HONG KONG
Tel: (852) 3428 6534
FAX Tel: (852) 3188 9145
Email: jlou@wannereng.com

Wanner Engineering, Inc.

1204 Chestnut Avenue
Minneapolis, MN 55403 USA
Tel: 612-332-5681
FAX Tel: 612-332-6937
Toll-Free Fax (USA): 800-332-6812
Email: sales@wannereng.com
www.Hydra-Cell.com/metering

Pump Ordering Information

A complete pump order number contains 13 digits based on the specified pump materials listed below. Contact your Hydra-Cell sales representative for accompanying motor drive options.

1	2	3	4	5	6	7	8	9	10	11	12	13
P	5	0	0									

Pump Model Size (Digits 1-4)

P500 For all P500 Pumps

Pump Version (Digit 5)

M BSPT Ports
N NPT Ports

Pump Head Material (Digit 6)

S 316 Stainless Steel
T Hastelloy®C

Diaphragm & O-ring Material (Digit 7)

G Viton®-XT
T Buna-N-XS

Check Valve Material (Digits 8-9)

(Valve Spring / Valve & Seat)
SS 316 SST / 316 SST
TT Hastelloy®C / Hastelloy®C

Gearbox Ratio (Digits 10-12)

A00	100:l	(71 B5 Motor Frame)	
H00*	100:l	(71 B5 Motor Frame)	> 104 bar
A80	80:l	(71 B5 Motor Frame)	
H80*	80:l	(80 B5 Motor Frame)	> 104 bar
A60	60:l	(71 B5 Motor Frame)	
H60*	60:l	(80 B5 Motor Frame)	> 104 bar
A50	50:l	(71 B5 Motor Frame)	
B50	50:l	(80 B5 Motor Frame)	
H50*	50:l	(80 B5 Motor Frame)	> 104 bar
A40	40:l	(71 B5 Motor Frame)	
B40	40:l	(80 B5 Motor Frame)	
H40*	40:l	(80 B5 Motor Frame)	> 104 bar
B30	30:l	(80 B5 Motor Frame)	
C30	30:l	(90 B5 Motor Frame)	
B25	25:l	(80 B5 Motor Frame)	
C25	25:l	(90 B5 Motor Frame)	
H25*	25:l	(90 B5 Motor Frame)	> 104 bar
B20	20:l	(80 B5 Motor Frame)	
C20	20:l	(90 B5 Motor Frame)	
H20*	20:l	(90 B5 Motor Frame)	> 104 bar
B15	15:l	(80 B5 Motor Frame)	
C15	15:l	(90 B5 Motor Frame)	
H15*	15:l	(90 B5 Motor Frame)	> 104 bar
B10	10:l	(80 B5 Motor Frame)	
C10	10:l	(90 B5 Motor Frame)	
H10*	10:l	(100 B5 Motor Frame)	
B07	7.5:l	(80 B5 Motor Frame)	
C07	7.5:l	(90 B5 Motor Frame)	
F07	7.5:l	(132 B14 Motor Frame)	
H07*	7.5:l	(112 B14 Motor Frame)	
G07	7.5:l	(132 B14 Motor Frame)	
B05*	5:l	(80 B5 Motor Frame)	
C05*	5:l	(90 B5 Motor Frame)	
E05*	5:l	(112 B14 Motor Frame)	
G05	5:l	(132 B14 Motor Frame)	

Base Plate (Digit 13)

A Aluminum (Epoxy painted)
G Carbon Steel (Epoxy painted) for all G reducers
H Carbon Steel (Epoxy painted) for all reducers with *