

P400 Pump Series

Capacities to 714.9 LPH - Rated to 70 Bar

Electronic Precision Metering

- Designed to handle a wide range of fluids from clear water to thick slurries
- Electronic flow control increases accuracy and reliability
- Multiple diaphragm design provides linear, virtually pulse-less flow
- Smaller footprint saves valuable space
- One pump covers a wide range of flows and pressures - reducing inventory requirements with fast, simple field conversion
- Duplexing option doubles capacity and equipment savings
- Hydraulically-actuated, balanced diaphragms provide superior performance across entire pressure range
- Rugged construction with a variety of affordable choices for liquid end, diaphragm and check valve materials



Hydra-Cell Metering Solutions meet or exceed API 675 performance standards for Steady-State Accuracy ($\pm 1\%$), Linearity ($\pm 3\%$), and Repeatability ($\pm 3\%$).

Performance*

LPH Maximum Flow at Designated Pressure

LPH All Pumps		LPH Metallic Pump Heads Only		Pump RPM	Gear Ratio	Motor RPM
7 Bar	17 Bar	35 Bar	70 Bar			
16.15	15.97	15.79	15.25	14.5	100:1	
20.80	20.61	20.41	19.81	18.13	80:1	
28.53	28.33	28.10	27.38	24.17	60:1	
34.72	34.50	34.25	33.43	29	50:1	
44.01	43.77	43.48	42.52	36.25	40:1	
59.48	59.22	58.85	57.67	48.33	30:1	1450
71.87	71.58	71.16	69.79	58	25:1	
90.44	90.12	89.62	87.97	72.5	20:1	
121.4	121.0	120.4	118.3	96.67	15:1	
183.3	182.8	181.9	178.9	145	10:1	
245.2	244.6	243.4	239.5	193.33	7.5:1	
369.0	368.2	366.5	360.7	290	5:1	
475.7	474.7	472.5	465.1	373.3	7.5:1	2800
714.9	713.4	710.2	699.2	560	5:1	

* Capacity data is shown for pumps with elastomeric diaphragms. Consult factory for performance characteristics of pumps with PTFE diaphragms.

Required Motor kW

0.18	0.37	0.55	0.75
1.1	1.5	2.2	

P400 Pump Series

Pump Data

Diaphragms per Liquid End	3
Flow Control	Electronic variable speed drive
Maximum Discharge Pressure	
Metallic Head:	70 bar (1000 PSI)
Non-Metallic Head:	Polypropylene- 17 bar (250 PSI) Kynar- 24 bar (350 PSI)
Maximum Suction Pressure	17 bar (250 PSI)
Maximum Temperature	
Metallic Head:	121 °C (250 °F)*
Non-Metallic Head:	60 °C (140 °F)
Suction Port	1 inch BSPT or NPT
Discharge Port	3/4 inch BSPT or NPT
Weight (less motor)	
Metallic Head:	28.1 kg (62 lbs)
Non-Metallic Head:	22.2 kg (49 lbs)
Dimensions (less motor)**	
Metallic Head:	447 mm W x 251 mm D x 263 mm H (17.59" W x 9.87" D x 10.34" H)
Non-Metallic Head:	462 mm W x 251 mm D x 263 mm H (18.19" W x 9.87" D x 10.34" H)

* Consult factory for correct component selection for fluid temperatures above 71 °C (160 °F).

** For 63 B5 motor frame only. Consult factory for other motor frame sizes.

Representative Dimensional Drawings (in mm)

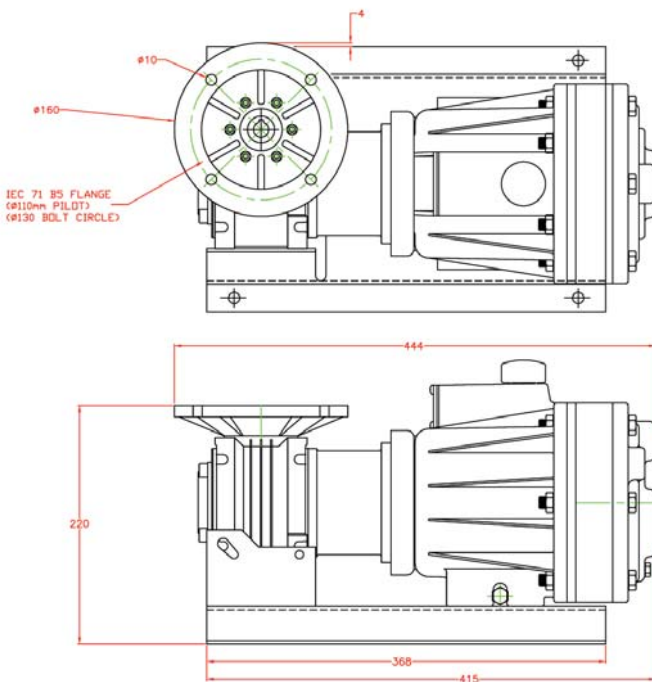

Hydra-Cell Metering Solutions pump systems are available with back pressure and relief valves, calibration cylinders, pulsation dampeners, manifolds and flanges, suction accumulators, custom controllers, strainers, a variety of actuating oils, witnessed and non-witnessed testing, drawing packages, and OEM paint and nameplate customization.

For information on the complete line of Hydra-Cell Metering Solutions pumps, contact us today.

Wanner International Ltd.

Units 8 & 9, Fleet Business Park
Sandy Lane
Church Crookham, Hampshire GU52 8BF, England
Tel: +(44) 01252 816847
FAX Tel: +(44) 01252 629242
Email: sales@wannerint.com
www.WannerInt.com

Printed in USA P400-DS-I-04.07

Wanner Pumps Ltd.

Room 1111, 11/F New Kowloon Plaza
38 Tai Kak Tsui Road
Tai Kak Tsui, Kowloon, HONG KONG
Tel: (852) 3428 6534
FAX Tel: (852) 3188 9145
Email: jlou@wannereng.com

Wanner Engineering, Inc.

1204 Chestnut Avenue
Minneapolis, MN 55403 USA
Tel: 612-332-5681
FAX Tel: 612-332-6937
Toll-Free Fax (USA): 800-332-6812
Email: sales@wannereng.com
www.Hydra-Cell.com/metering

Pump Ordering Information

A complete pump order number contains 13 digits based on the specified pump materials listed below. Contact your Hydra-Cell sales representative for accompanying motor drive options.

1	2	3	4	5	6	7	8	9	10	11	12	13
P	4	0	0									

Pump Model Size (Digits 1-4)

P400 For all P400 Pumps

Pump Version (Digit 5)

M BSPT Ports
N NPT Ports

Pump Head Material (Digit 6)

C Cast Iron
M Kynar®
P Polypropylene
S 316 Stainless Steel
T Hastelloy®C

Diaphragm & O-ring Material (Digit 7)

E EPDM
G Viton®-XT
J PTFE
P Neoprene
T Buna-N-XS

Check Valve Material (Digits 8-9)

(Valve Spring / Valve & Seat)

SS 316 SST / 316 SST
TT Hastelloy®C / Hastelloy®C
SC 316 SST / Ceramic
TC Hastelloy®C / Ceramic

Gearbox Ratio (Digits 10-12)

100	100:1	(63 B5 Motor Frame)
080	80:1	(63 B5 Motor Frame)
060	60:1	(63 B5 Motor Frame)
050	50:1	(63 B5 Motor Frame)
040	40:1	(63 B5 Motor Frame)
A30	30:1	(71 B5 Motor Frame)
A25	25:1	(71 B5 Motor Frame)
A20	20:1	(71 B5 Motor Frame)
A15	15:1	(71 B5 Motor Frame)
A10	10:1	(71 B5 Motor Frame)
B10	10:1	(80 B5 Motor Frame)
A07	7.5:1	(71 B5 Motor Frame)
B07	7.5:1	(80 B5 Motor Frame)
C07	7.5:1	(90 B5 Motor Frame)
B05	5:1	(80 B5 Motor Frame)
C05	5:1	(90 B5 Motor Frame)

Base Plate (Digit 13)

C Carbon Steel (Epoxy painted)
S Stainless Steel